

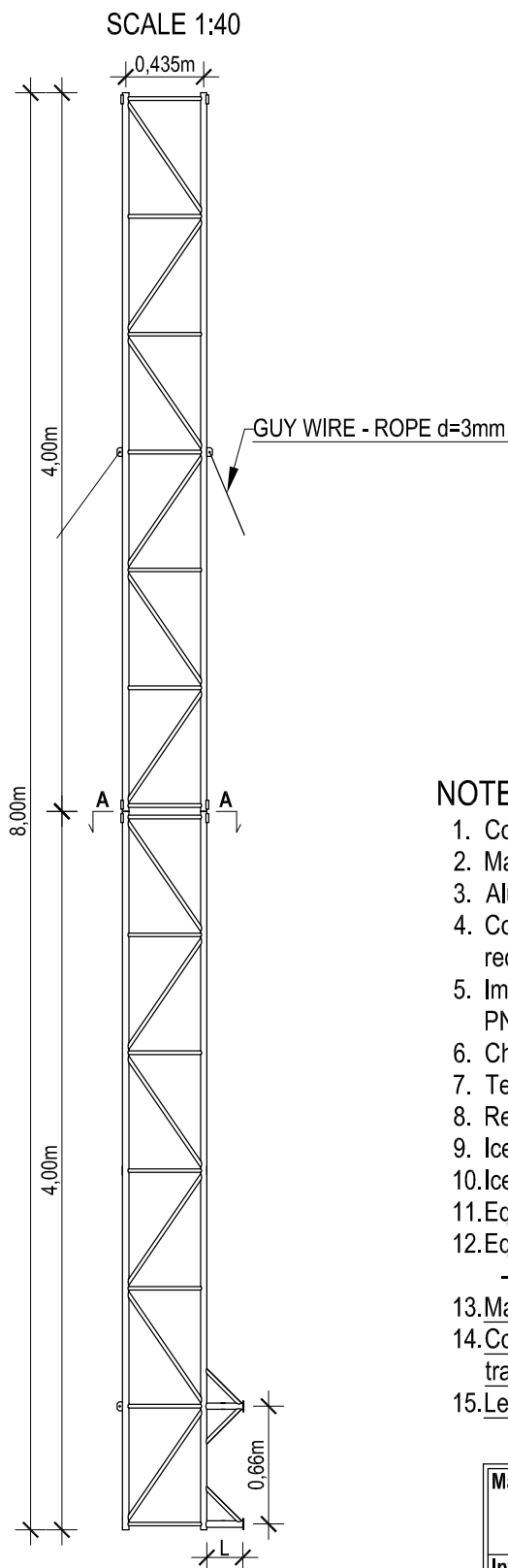

ASSEMBLY DRAWING

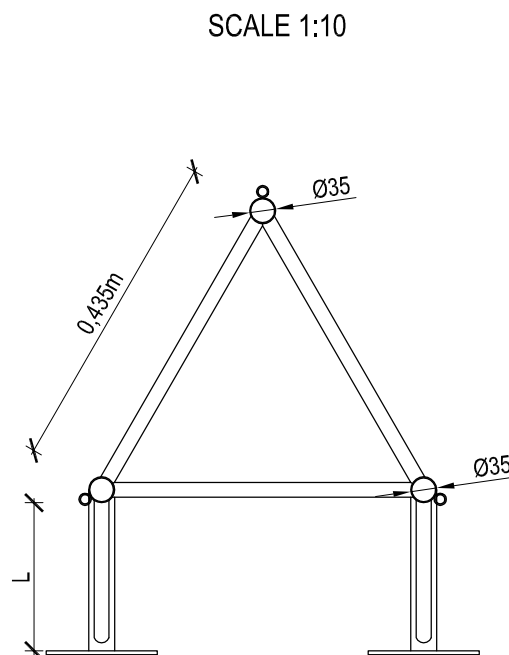

SECTION A-A



NOTES :

1. Construction of M435B/H08 - side fastened
2. Mast separation distance from the wall (L): 20 lub 40 cm
3. Aluminum alloy: EN AW-6005A T6
4. Connections: fillet welded with TIG (GTAW) argon method by the requirements of ISO 3834-2
5. Implementation class structure by the requirements of PN-EN-1090-3: EXC3
6. Characteristic wind speed: $V_k=22\text{m/s}$
7. Terrain category: II
8. Reliability class: II
9. Ice density: 700kg/m^3
10. Ice thickness: 2,0cm
11. Equipment total weight limit on the mast: 40kg
12. Equipment area on the mast:
- $S=0,5\text{m}^2$ on the whole mast
13. Mast must be set under construction law
14. Construction, on which mast will be located, must be able to transfer reactions
15. Lead assembly with wind speed not more than 5m/s

Manufacturer: RETIS WWW.RETIS.PL WWW.MASZTY-RETIS.PL			
Investment: SERIES OF ALUMINUM LATTICE MASTS - TYPE - M435B			
Drawing title: MAST WITH SIDE FASTENED M435B/H08			
Date: 04.2014	Phase: typical project	Project No.: RETIS M435B	Revision: ...
Industry: construction	Project No.: RETIS_KK_M435B_H08		