



RETIS[®]
CONSTRUCTION

TYPICAL MAST M300/H12

ASSEMBLY DRAWING

SCALE 1:50

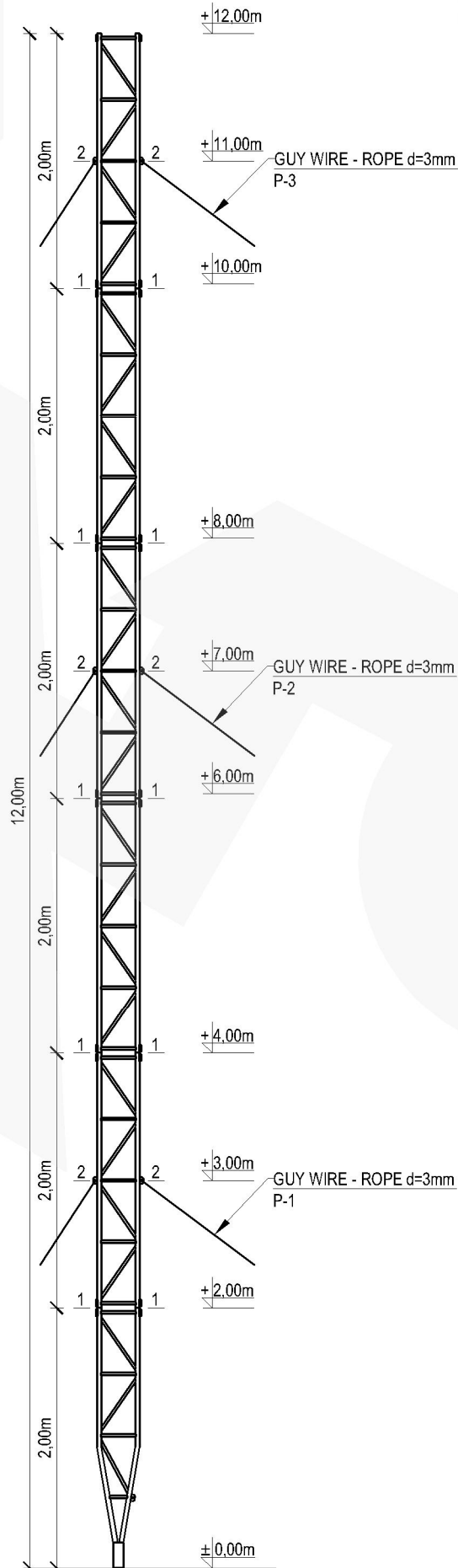

GUY WIRES RANGE

SCALE 1:150

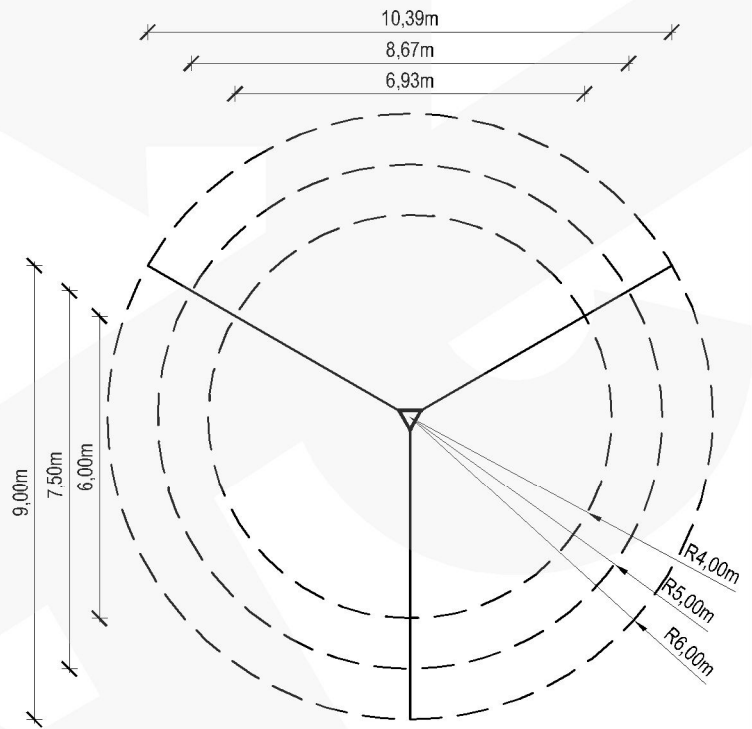

NOTES :

1. Typical mast construction M300/H12
2. Aluminum alloy: EN AW-6005A T6
3. Connections: fillet welded with TIG (GTAW) argon method by the requirements of ISO 3834-2
4. Results may vary depending on local geometry and mast foundation
5. Characteristic wind speed: $V_k=22\text{m/s}$
6. Terrain category: II
7. Reliability class: II
8. Ice density: 700kg/m^3
9. Ice thickness: 2,0cm
10. Equipment total weight limit on the mast: 60kg
11. Equipment area on the mast:
- $S=0,5\text{m}^2$ at the top of the mast
12. Mast must be set under construction law
13. Construction on which mast will be located must be able to transfer reactions
14. Lead assembly with wind speed not more than 5m/s
15. Guy wires: steel ropes 3mm $R_m=1770\text{MPa}$ T1x19 by EN 12385
16. Initial tension of guy wires: from 8% to 15% of rated breaking strength of the guy

Manufacturer:			
RETIS WWW.RETIS.PL WWW.MASZTY-RETIS.PL			
Investment:			
SERIES OF ALUMINUM LATTICE MASTS - TYPE - 300			
Drawing title:			
TYPICAL MAST M300/H12 - ASSEMBLY DRAWING + GUY WIRES RANGE			
Date:	Phase:	Project No.:	Revision:
05.2013	typical project	RETIS M300	...
Industry:	Project No.:		
construction	RETIS_KK_M300_H12_01		



SECTION 1-1

SCALE 1:10

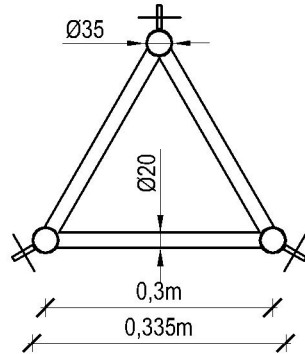

SECTION 2-2

SCALE 1:10

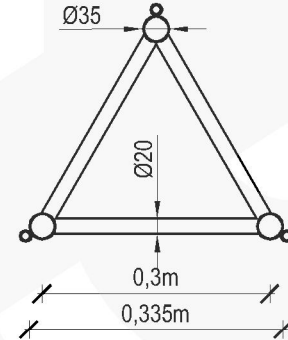

Rope fi 3mm (1x19)	Clamps 3mm	Patent eye 3mm
105mb	54szt.	18szt.
Shackle 8mm	Simple washer M8	Selflocking nut M8
9szt.	30szt.	30szt.
Simple nut M8	Screw M8x180	Roman screw
30szt.	15szt.	9szt.
Lightning tip	Caps	Base
1szt.	3szt.	kpl.

NOTES :

1. Typical mast construction M300/H12
2. Aluminum alloy: EN AW-6005A T6
3. Connections: fillet welded with TIG (GTAW) argon method by the requirements of ISO 3834-2
4. Results may vary depending on local geometry and mast foundation
5. Characteristic wind speed: $V_k=22\text{m/s}$
6. Terrain category: II
7. Reliability class: II
8. Ice density: 700kg/m^3
9. Ice thickness: 2,0cm
10. Equipment total weight limit on the mast: 60kg
11. Equipment area on the mast:
- $S=0,5\text{m}^2$ at the top of the mast
12. Mast must be set under construction law
13. Construction on which mast will be located must be able to transfer reactions
14. Lead assembly with wind speed not more than 5m/s
15. Guy wires: steel ropes 3mm Rm=1770MPa T1x19 by EN 12385
16. Initial tension of guy wires: from 8% to 15% of rated breaking strength of the guy

Manufacturer: RETIS WWW.RETIS.PL WWW.MASZTY-RETIS.PL			
Investment: SERIES OF ALUMINUM LATTICE MASTS - TYPE-300			
Drawing title: TYPICAL MAST M300/H12 - SECTIONS + LIST OF ELEMENTS			
Date: 06.2013	Phase: typical project	Project No.: RETIS M300	Revision: ...
Industry: construction		Project No.: RETIS_KK_M300_H12_02	